

CORE INSPECTION GUIDELINES

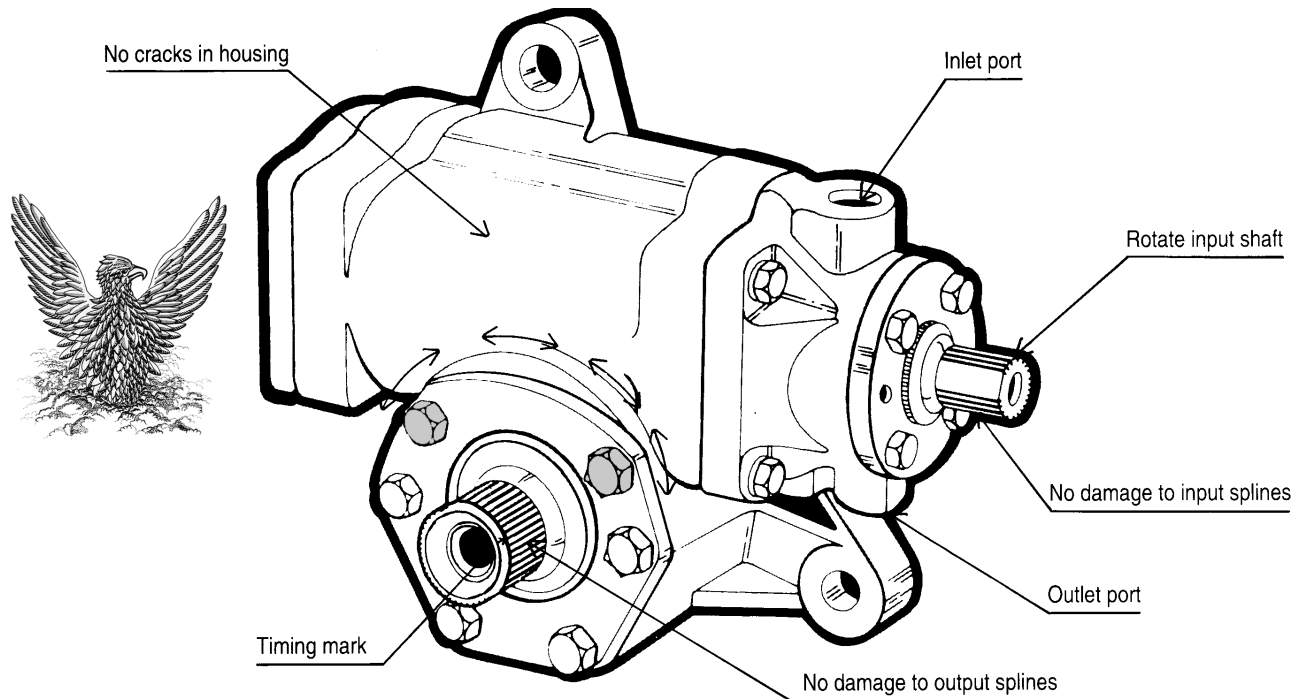

Core to be returned must be like for like.

PLEASE CHECK THE FOLLOWING BEFORE ISSUING CREDIT TO YOUR CUSTOMER!!

1. Core must turn freely from end to end. Locked up gears will not be considered for core credit.
2. Gears with twisted or broken shafts will not be considered for core credit.
3. Wrecked gears or salvage yard gears will not be considered for core credit.
4. Gear with worn splines on sector shaft or input shaft, or with pitman arms or yokes welded to them will have a core credit deduction. PLEASE CALL for deduction amount!!!
5. Gears must be drained of all oil, plugged to prevent leaks, must be fully assembled, have no extra parts attached and be shipped in a suitable shipping container.

Failure to follow these guidelines may result in partial or no core credit issued!!