

DriveMaster™

FAN DRIVE INSTALLATION, OPERATION AND MAINTENANCE INSTRUCTIONS

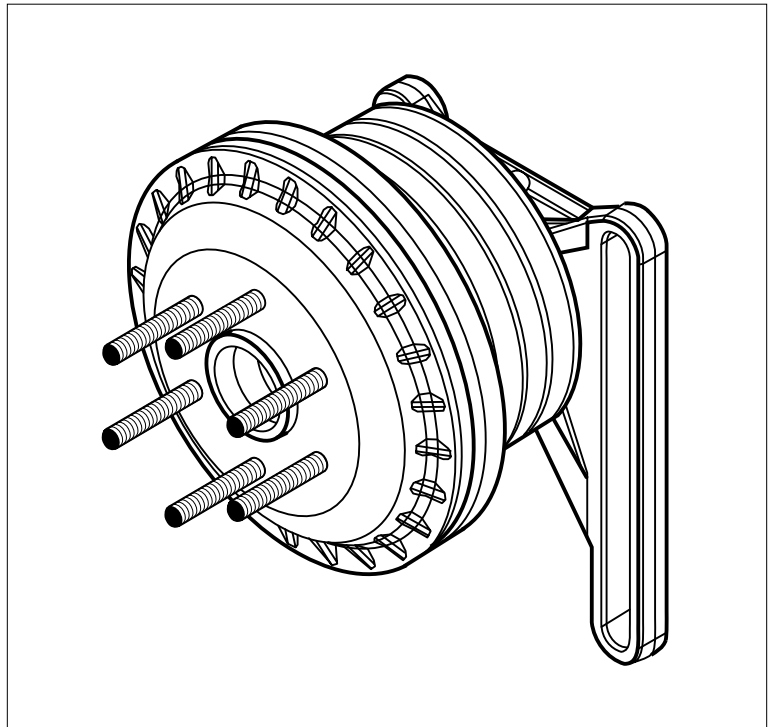

| | |
|---|-----------|
| INTRODUCTION | 3 |
| General Information | 3 |
| PREVENTIVE MAINTENANCE | 4 |
| PRE-INSTALLATION | 6 |
| INSTALLATION | 7 |
| Vehicle Preparation | 7 |
| Fan Drive Installation | 7 |
| ELECTRICAL CONNECTIONS | 10 |
| Electrically Normally Closed (N.C.) | 10 |
| Electrically Normally Open (N.O.) | 12 |
| Electronically Controlled Engines | 14 |

INTRODUCTION

General Information

This manual describes the correct Fan Drive Installation procedures. Following the instructions carefully will provide the safest and most trouble-free operation.

Horton uses the following special notices to give warning of possible safety related problems which could cause serious injury and provide information to help prevent damage to equipment.



Danger is used to indicate the presence of a hazard which will cause severe personal injury, death, or substantial property damage if the warning is ignored.



Warning is used to indicate the presence of a hazard which can cause severe personal injury, death, or substantial property damage if the warning is ignored.



Caution is used to indicate the presence of a hazard which will or can cause minor personal injury or property damage if the warning is ignored.

NOTE

Note is used to notify people of installation, operation, or maintenance information which is important but not hazard related.

PREVENTIVE MAINTENANCE

Vehicle Preparation

1. Before performing work on the Fan Drive, be sure to follow good shop safety practices. Turn the vehicle ignition off, apply the vehicle's parking brake, and block the vehicle's wheels.



WARNING

Be sure engine is turned off and fan has stopped turning before approaching fan area, to prevent serious personal injury.

2. Before doing work in the area of the fan:
 - Start the vehicle's engine and build air pressure in excess of 90 PSI.
 - Manually engage and disengage the Fan Drive. Observe the fan and Fan Drive from a distance, look for vibration, fan blade contact, Fan Drive slippage, and Fan Drive operation.
 - Turn Engine off.

Each Week

Drain Air Filter (if equipped).

If moisture or contamination is detected, the filter must be disassembled and flushed thoroughly with clean parts solvent. Dry carefully before reassembly. Determine the cause of the moisture or contamination and correct the condition.

Every 25,000 Miles

Fan and Fan Belt

Fan and Fan Belt problems can cause product failure if left unattended.

1. Check the fan for looseness and damage, such as bent, cracked or missing blades, loose rivets or missing weights. Retorque if loose. Replace if damaged.
2. Check for adequate clearance between the fan and the fan shroud or other engine compartment components in both the engaged mode the and disengaged mode. Repair if the clearance is inadequate.
3. Check the fan belt condition, belt tension, and belt alignment. Correct if necessary.

PRE-INSTALLATION

You must follow your company safety practices, which should adhere to or be better than Federal or State approved shop safety practices and procedures. Be sure that you understand all the procedures and instructions before you begin work on this unit.

NOTE

Parts replacement and/or repair of your Horton DRIVEMASTER™ Fan Drive should be performed only by the Horton Factory or an authorized Horton Distributor or Dealer to keep your warranty coverage intact during the warranty period.

Before installation of your Horton DRIVEMASTER Fan Drive, note the Fan Drive Serial No., Service Part No., Date of Installation, and Vehicle Mileage.

Serial No. _____

Service Part No. _____

Installation Date _____

Vehicle Mileage _____

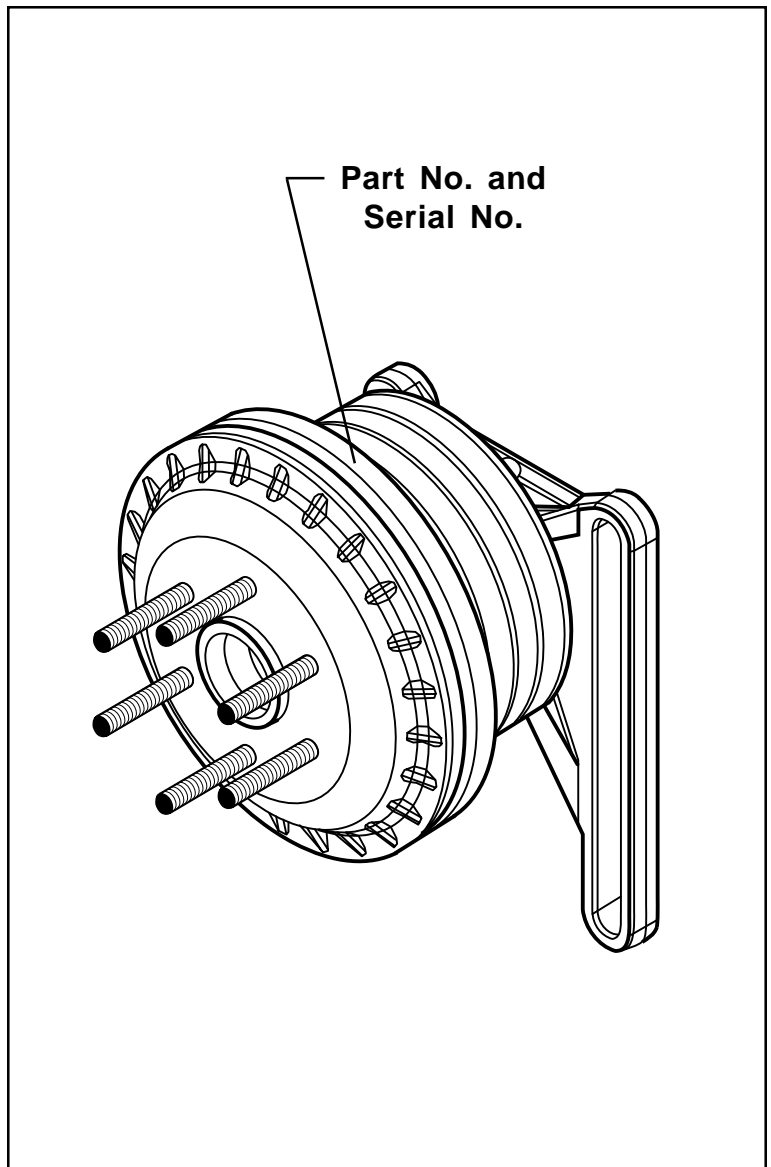

INSTALLATION

Vehicle Preparation

1. Turn the vehicle ignition off, apply the vehicle's parking brake, and block the vehicle's wheels.

NOTE

Protect the radiator from possible damage from the fan during fan removal and fan drive installation.

2. If applicable, remove the existing fan, fan drive, mounting hardware and belts.

Fan Drive Installation

1. Position the Horton Fan Drive on the engine and align the holes for mounting.

NOTE

Most engines have multiple mounting locations. Be sure to use the correct holes for the application.

2. Tighten the SAE Grade 8 mounting bolts and/or nuts to the vehicle manufacturer's specifications.



CAUTION

Correct belt adjustment and alignment is necessary for all belt driven components to assure longevity of component life. Over tightening of belts will shorten bearing life. Loose belts will cause excessive belt wear and shorten bearing life. Consult the equipment manufacturer and/or engine manufacturer specifications for proper belt adjustment.

3. Replace and adjust the belts.

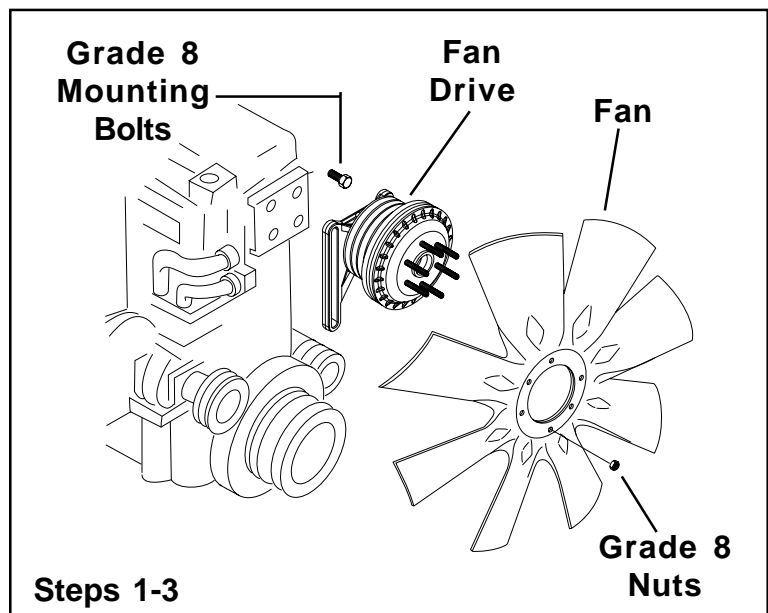

NOTE

Some Horton Fan Drives incorporate a belt tension feature into the Fan Drive mounting bracket. Use this feature if applicable.



WARNING

The maximum fan diameter is 32". If a larger fan diameter is required, contact Horton at 1-800-621-1320.

4. Mount the fan onto the Fan Drive and tighten the bolts and/or nuts to the vehicle manufacturer's specifications.
5. Drain the appropriate amount of engine coolant from the system before thermal switch installation.
6. Remove the pipe plug from the engine coolant manifold and install the Thermal Switch. (Location of the pipe plug may vary.)

NOTE

Locate the Thermal Switch as close to the engine coolant thermostat as possible. The Thermal Switch setting should engage the Fan Clutch at least 10° F higher than the engine thermostat setting.

7. Mount the Solenoid Valve in an upright position on either the vehicle's fire wall or radiator support, in an area where the Solenoid Valve will not be subjected to engine heat, vibration, or road dirt.
8. Connect an air hose from the vehicle's air supply to the Solenoid Valve inlet port.



WARNING

The vehicle's air supply must be clean and free of moisture and oil.

9. Check for proper air pressure to the Fan Drive. This measurement should always be taken at the Fan Clutch air inlet port.

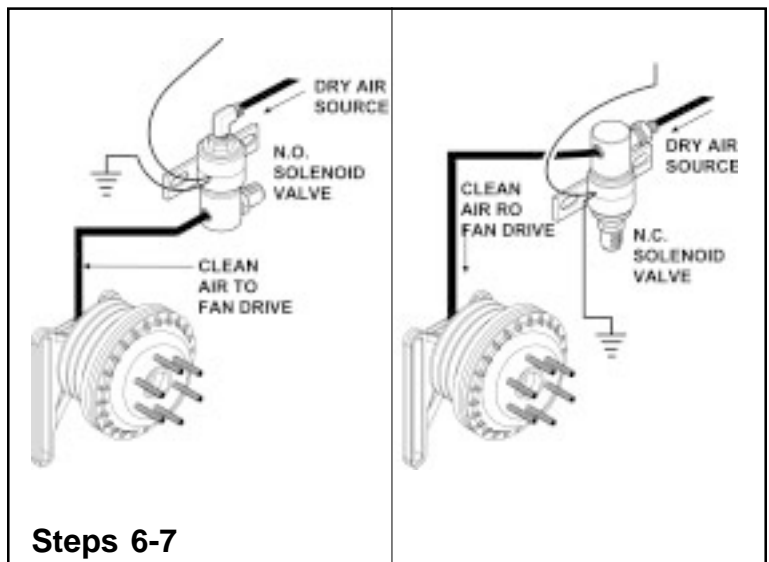
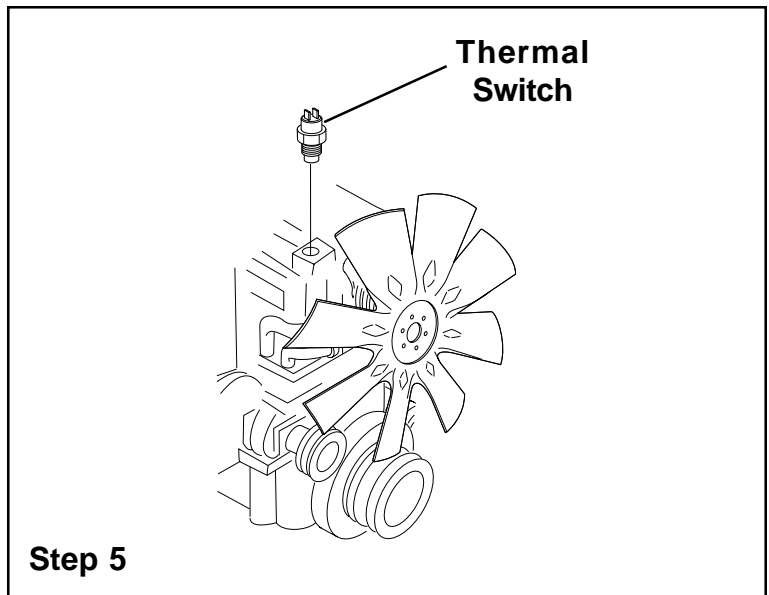

NOTE

To assure maximum performance of the Fan Drive and to prevent damage to the Fan Clutch, there must be a minimum pressure of 90 PSI to the Fan Drive upon disengagement.

9. Affix the WARNING sticker to a highly visible area of the engine compartment.

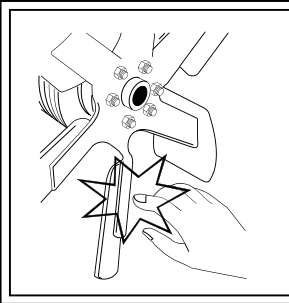
| | |
|--|---|
|  | <p>! WARNING</p> <p>This vehicle is equipped with a Horton Fan Clutch. Keep hands away from fan when engine is running. Clutch can engage without warning.</p> |
|--|---|

Step 9

ELECTRICAL CONNECTIONS

Electrically Normally Closed (N.C.)

NOTE

The Horton DRIVEMASTER™ Fan Drive is spring engaged, air disengaged. An electrical system wired N.C. will require a normally closed Solenoid Valve.

Also note the N.C. Thermal Switch, N.C. Freon Pressure Switch, and N.C. Solenoid Valve are the only controls absolutely necessary for fan clutch operation. The N.C. manual Switch, Air Pressure Switch, and Indicator Light are all optional controls and may be left out of the circuit.

1. Remove the battery cables from the battery.
2. Install the Air Pressure Switch into the air line between the N.C. Solenoid Valve and the Fan Drive.
3. Mount the optional Indicator Light and Toggle Switch on the dashboard or other convenient location.

NOTE

The Manual Toggle Switch is stamped OFF and ON. OFF position is for continuous operation, ON position is for automatic operation. Set the Manual Toggle Switch to ON position and note this position for future reference.

4. Install the N.C. Freon Pressure Switch into the high pressure Freon line of the air conditioning system.
5. Connect the Black lead of the N.C. Solenoid Valve to the vehicle ground.
6. Connect the Red (12 Volt) or Green

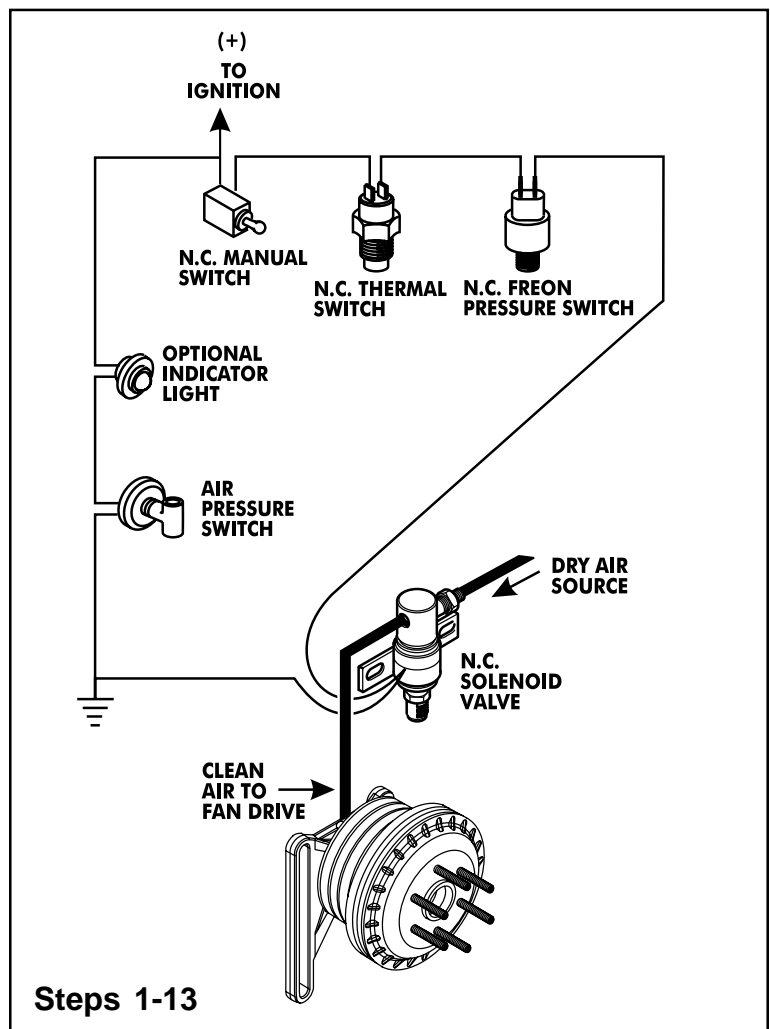

(24 Volt) lead of the N.C. Solenoid Valve to one lead of the N.C. Freon Pressure Switch.

7. Connect the other lead of the N.C. Freon Pressure Switch to one terminal of the N.C. Thermal Switch.
8. Connect the other terminal of the N.C. Thermal Switch to one terminal of the Manual Toggle Switch.
9. Connect the other terminal of the Manual Toggle Switch to the vehicle accessory or ignition terminal.
10. Connect one terminal of the Air Pressure Switch to the vehicle ground.
11. Connect the other terminal of the Air Pressure Switch to the Indicator Light.

NOTE

If using the Air Pressure Switch, it must be installed in the air line between the Solenoid Valve and the Fan Drive. Minimize the length of air line between each of these components.

12. Connect the other terminal of the Indicator Light to the vehicle accessory or ignition terminal.
13. Connect the battery cable to the battery.

Electrical System Operation Check



WARNING

Keep hands and tools clear of the fan blades. The Fan Drive can engage without warning.

1. With the engine temperature below the Thermal Switch setting, turn on the ignition and build up air pressure.

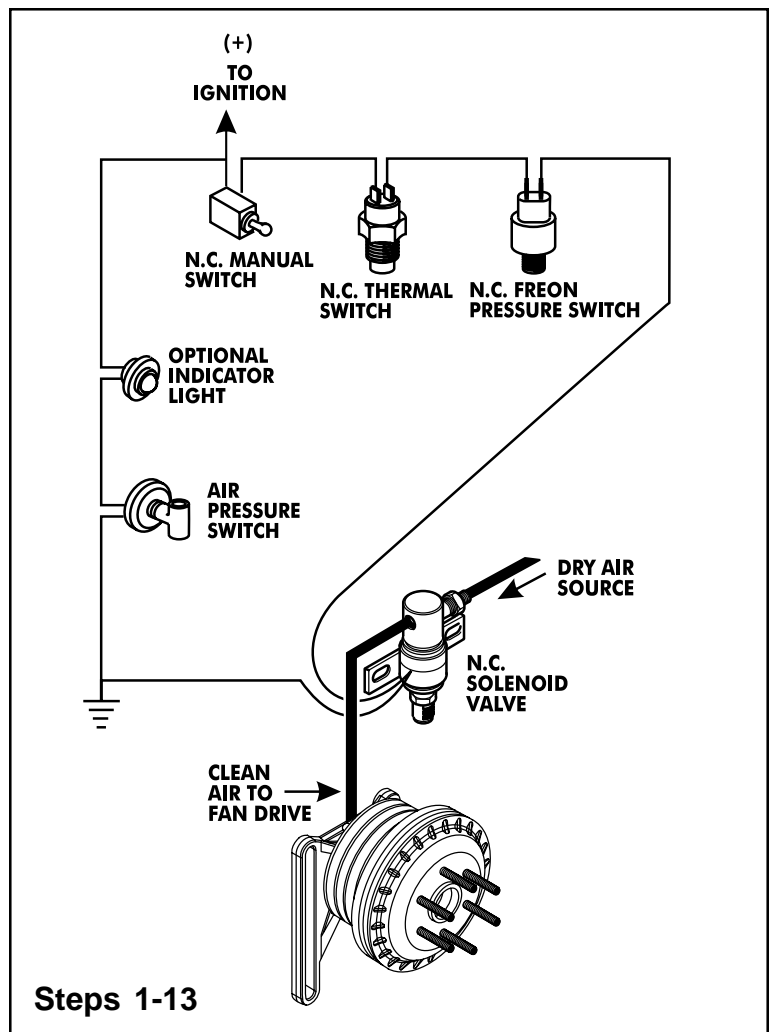

2. Disconnect one terminal of the N.C. Thermal Switch. This will engage the Fan Drive (air should exhaust from the N.C. Solenoid Valve).
3. Reconnect the terminal of the N.C. Thermal Switch. This will disengage the Fan Drive.
4. Repeat Steps 1-3 for the N.C. Freon Pressure Switch.
5. Set the Manual Toggle Switch to OFF. The Indicator Light will come on when the Fan Drive is engaged. If the Indicator Light does not come on, check the bulb and the Indicator Light's ground connection.

NOTE

ON position is for automatic operation, OFF position is for continuous operation.

Electrically Normally Open (N.O.)

NOTE

The Horton DRIVEMASTER™ Fan Drive is spring engaged, air disengaged. An electrical system wired N.O. will require a N.O. Solenoid Valve.

Also note the N.O. Thermal Switch, N.O. Freon Pressure Switch, and N.O. Solenoid Valve are the only controls absolutely necessary for fan clutch operation. The N.O. manual Switch, Air Pressure Switch, and Indicator Light are all optional controls and may be left out of the circuit.

1. Remove the battery cables from the battery.
2. Install the Air Pressure Switch into the air line between the N.O. Solenoid Valve and the Fan Drive.
3. Mount the Indicator Light and Toggle Switch on the dashboard or other convenient location.

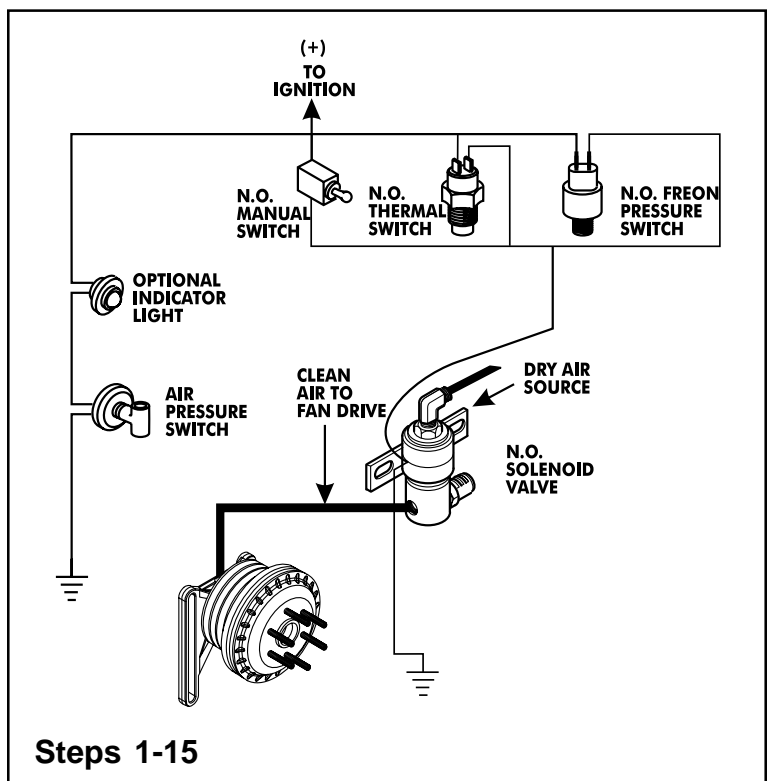

NOTE

The Manual Toggle Switch is stamped OFF and ON. ON position is for continuous operation, OFF position is for automatic operation. Set the Manual Toggle Switch to OFF position and note this position for future reference.

4. Install the N.O. Freon Pressure Switch into the high pressure Freon line of the air conditioning system.
5. Connect the Black lead of the N.O. Solenoid Valve to the vehicle ground.
6. Connect the Red (12 Volt) or Green (24 Volt) lead of the N.O. Solenoid Valve to one terminal of the N.O. Thermal Switch.
7. Connect the other terminal of the N.O. Thermal Switch to the vehicle accessory or ignition terminal.
8. Connect one lead of the Manual Toggle Switch to the Red (12 Volt) or Green (24 Volt) lead connecting the N.O. Solenoid Valve to the terminal of the N.O. Thermal Switch.
9. Connect the other lead of the Manual Toggle Switch to the vehicle accessory or ignition terminal.
10. Connect one lead of the N.O. Freon Pressure Switch to the Red (12 Volt) or Green (24 Volt) lead connecting the N.O. Solenoid Valve to the terminal of the N.O. Thermal Switch.
11. Connect the other lead of the N.O. Freon Pressure Switch to the vehicle accessory or ignition terminal.
12. Connect one lead of the Air Pressure Switch to the vehicle ground.

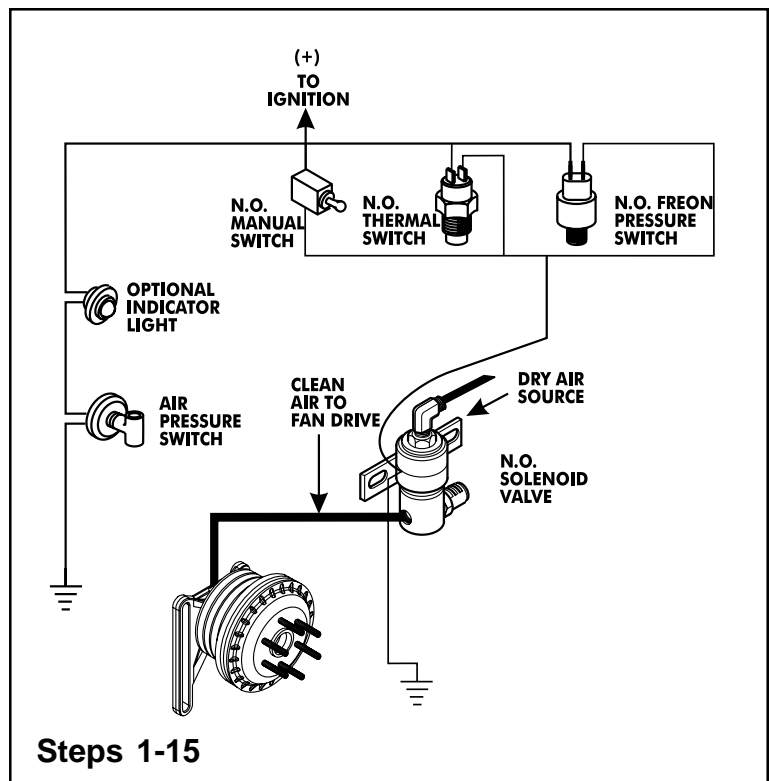

13. Connect the other lead of the Air Pressure Switch to one terminal of the Indicator Light.
14. Connect the other terminal of the Indicator Light to the vehicle accessory or ignition terminal.
15. Connect the battery cables to the battery.

Electrical System Operation Check



WARNING

Keep hands and tools clear of the fan blades. The Fan Drive can engage without warning.

1. With the engine temperature below the Thermal Switch setting, turn on the ignition and build up air pressure.
2. Install a jumper wire between the terminals of the N.O. Thermal Switch, this will engage the Fan Drive (air should exhaust from the N.O. Solenoid Valve).
3. Remove the jumper wire from the N.O. Thermal Switch. This will disengage the Fan Drive.
4. Repeat Steps 1-3 for the N.O. Freon Pressure Switch.
5. Set the Manual Toggle Switch to ON. This will engage the Fan Clutch, the Indicator Light will light when the Fan Drive is engaged. If the Indicator Light fails to light, check the bulb and the Indicator Light's ground connection.

NOTE

OFF position is for automatic operation, ON position is for continuous operation.

Electronically Controlled Engines

Installation of Drivemaster Fan Drives in Electronically Controlled Engines must be performed by a factory authorized service center. Contact your dealer for the location nearest you.

NOTES



Horton, Inc.
P.O. Box 9455
Minneapolis, MN 55440-9455
(612) 331-5931
1-800-621-1320
FAX: (612) 627-5700
www.hortoninc.com

©1999 Horton, Inc.
All rights reserved. Printed in U.S.A.

22656-B-0899